

Article type : Research Article

Date Received : 01/10/2020

Date Accepted : 22 /10/2020

Date published : 01/12/2020



: www.minarjournal.com

<http://dx.doi.org/10.47832/2717-8234.4-2.7>



MODELING AND ANALYSIS OF FIVE REGIONS FIBER BRAGG GRATING USING OPTISYSTEM SOFTWARE SIMULATION

Riyam Skakir MOHAISEN¹ & Suha Mousa KHORSHEED²

Abstract

This paper describes the concept and simulation of an fiber Bragg grating. Simulation of the transmission system have been analyzed using simulator OptiSystem, based on different parameters. Show there parameters are investigated by simulating a communication device model and using the most suitable system settings which include input power (dBm), fiber cable length (km) and attenuation coefficient (dB / km) in the cable segment; Namely, signal strength (dB), noise power (dB), receiver output (watts). The power values (-5.299 dB) and (-2.6635 dB) are found in which regions, which decrease as the number of network regions in the fiber increases, thus increasing the density efficiency (16.316) and (75.5192) as well as the number of fiber regions (FBG).

Keywords: Principle of FBG, Reflectivity and Transmission Spectrum in FBG, Periodic in FBG, Optisystem, Attenuation Coefficient.

¹ Al-Nahrain University, Iraq, Suhaalawsi@gmail.com

² Al-Nahrain University, Iraq, riyamshakir5@gmail.com, <https://orcid.org/0000-0002-3062-1145>

1. Introduction

Optical fiber is one of the most important newspapers in the networking system. It is used in high-speed data transfer due to its versatile benefits and negligible loss of transmission. While there are many advantages to optical fiber communication, dispersion is the main limiting factor in efficiency. There are many optical fiber types, usually selected as critical components to compensate for dispersion in the optical communication network, the Fiber Bragg Grating (FBG). Due to the low cost of the filter for wavelength selection and low insert loss of insert, this has also tailored reflection spectrum and broad bandwidth, fiber optics is a medium used to move information in the form of light from one point to another. Fiber optics are not electric in nature, unlike the copper method of transmission.[1]. A simple fiber optic system consists of a transmission device emitting a signal of light; a fiber optic cable carrying the light, and a receiver, which embraces the transmitted light signal. The fiber is passive in itself and contains no active, generative properties. This (fibre optic system) theory is shown in figure 1 [2].

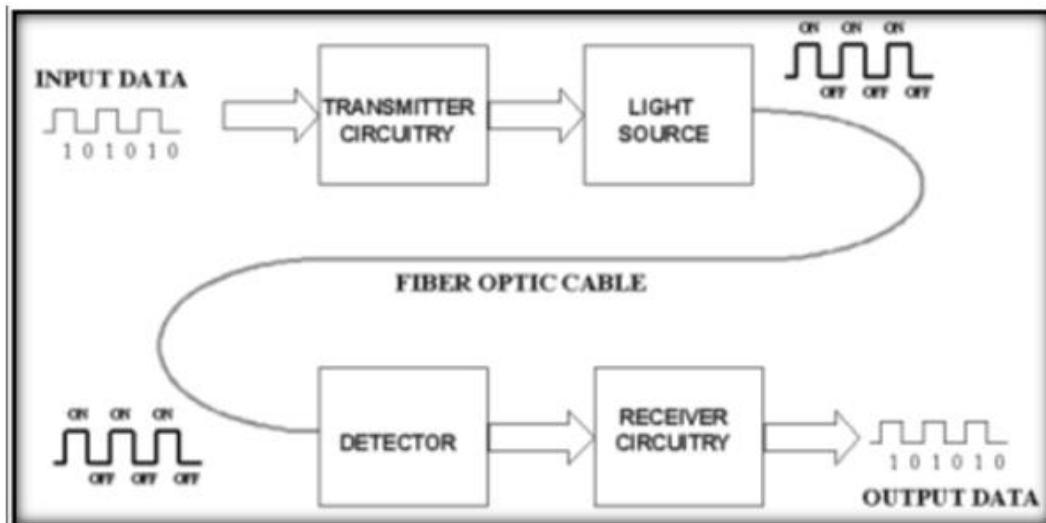

Figure(1): Basic system of fiber optic communication [3].

Fiber Bragg Grating (FBG) has the advantages of a simple structure, low insertion loss, high selectivity of wavelength, insensitivity to polarization and maximum compatibility with optical fibers in general single mode communication [4]. FBG The narrow spectral component of the light that is directed at the Bragg wavelength in the optical fiber core depends on the fiber grating time and the refractive index of the optical fiber. FBG is one mode that will be provided with an intensive UV fundamental periodic pattern[5]. This leads to greater sensitivity to the refractive index and thereby permanently raises the refractive index. The formation of the exposure pattern would then be formed called fixed index grating [6]. Only a small range of light wavelengths corresponding to the Bragg wavelength will be reflected when a light source is transmitted to the FBG, transmitting this spectral data to the attached FBG spectrum analyzer. All other wavelengths will partially reflect and interfere destructively with small index variations, causing the transmission of those wavelengths. This principle is shown in figure 2 [7].

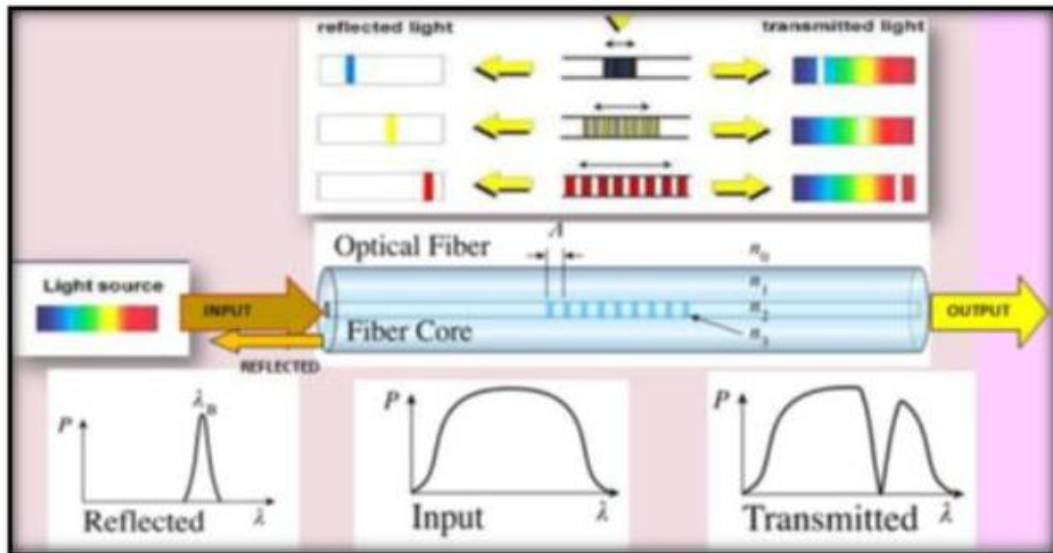

Figure(2): The principle of Bragg's light [8].
Table (1): List of Abbreviations

Abbreviation	Meaning
FBG	Fiber Bragg grating
UV	Ultraviolet
CW	Continuous Wave
NRZ	Non-return to Zero
BER	Bit-Error-Rate
WDM	Wavelength division multiplexing

1. System Design

Optisystem is a simulation package of optical communication systems that designs, tests and optimizes virtually any form of optical connection in the physical layer of a wide range of optical networks. It is a system level simulator focused on the practical modeling of fiber-optic communication systems. To give inputs in one region and five ports in the second region, a single continuous laser wave source is used. To simulate a wavelength Division multiplexing optical array, the transmit frequency of a CW laser array starts at 1550nm with 10 GHz channel spacing. The optical input source has a power of 0 dBm. The two separate subsystems function as a water demand management transmitter. The circuit multiplexer consists of four subsystems (from Tr1 to Tr4). The expanding subsystem includes an NRZ pulse generator, a Mach-Zehnder modulator, a continuous wave laser, and a pseudo-random bit sequence generator. When 0.205 dB / cm attenuation is achieved, the multiplexed signal is released into a 10 cm wide single-mode optical fiber, as shown in the following designs:

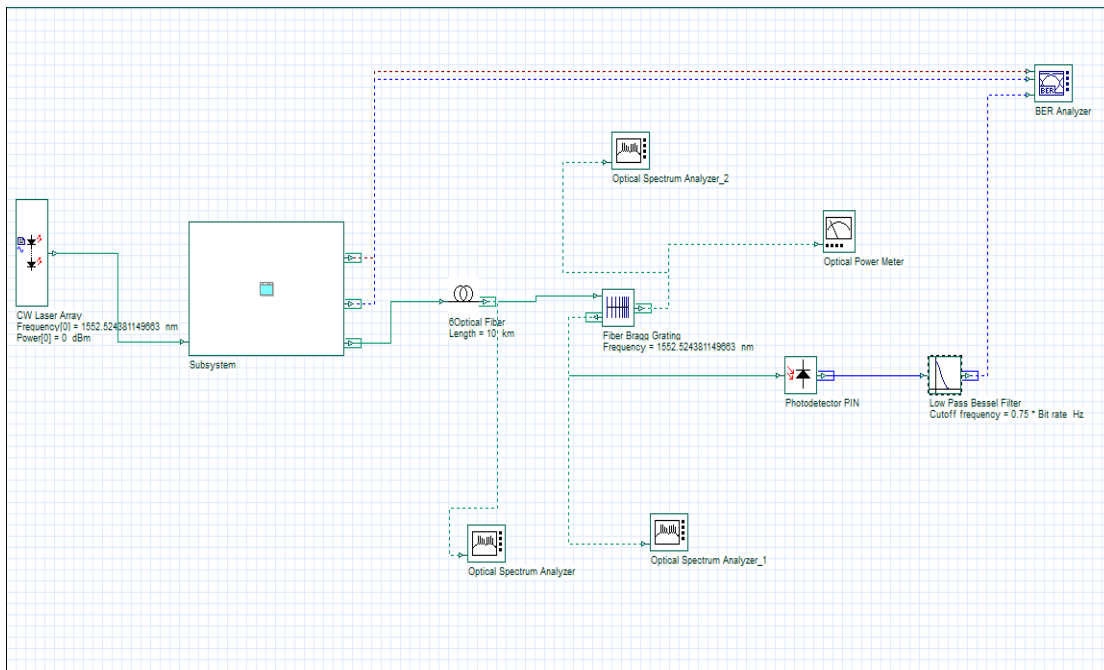
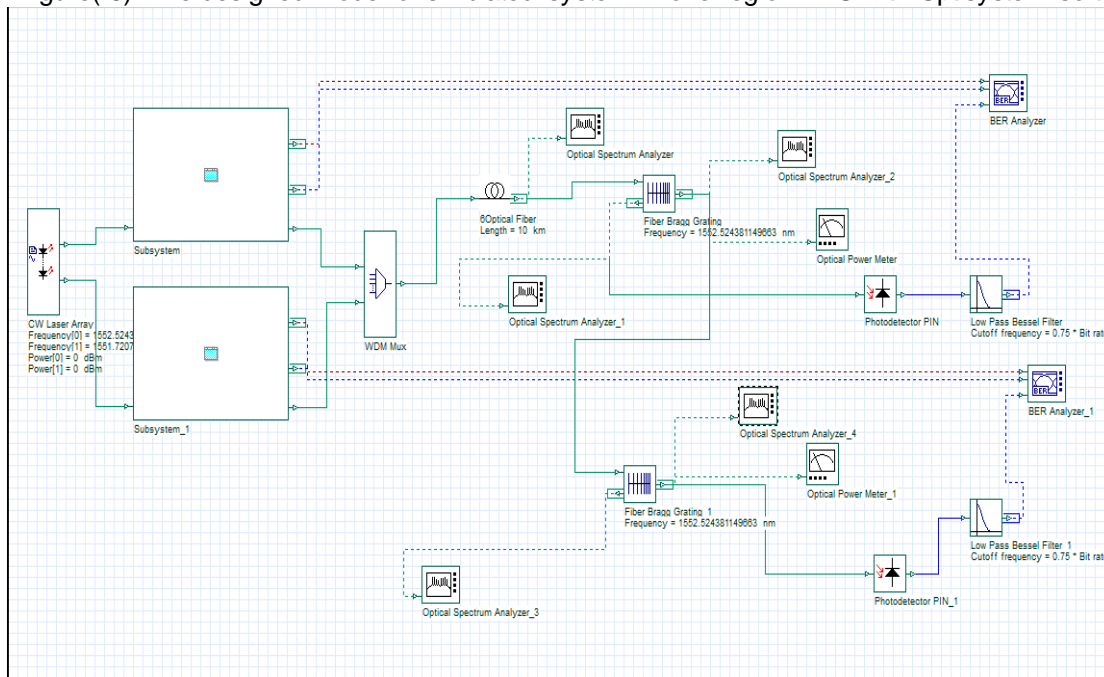

Figure (3): The designed model of simulated system in one region FBG with Optisystem software.



Figure(4):. The designed model of simulated system in two regions FBG with Optisystem software.

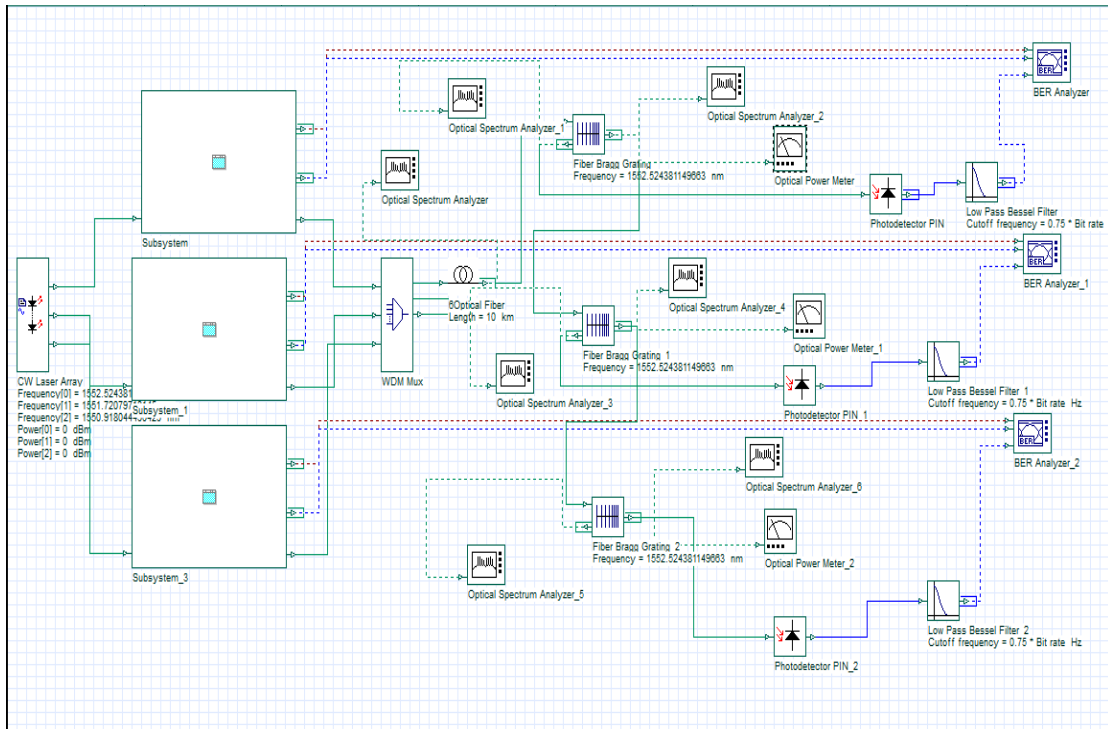

Figure (5): The designed model of simulated system in three regions FBG with Optisystem software.

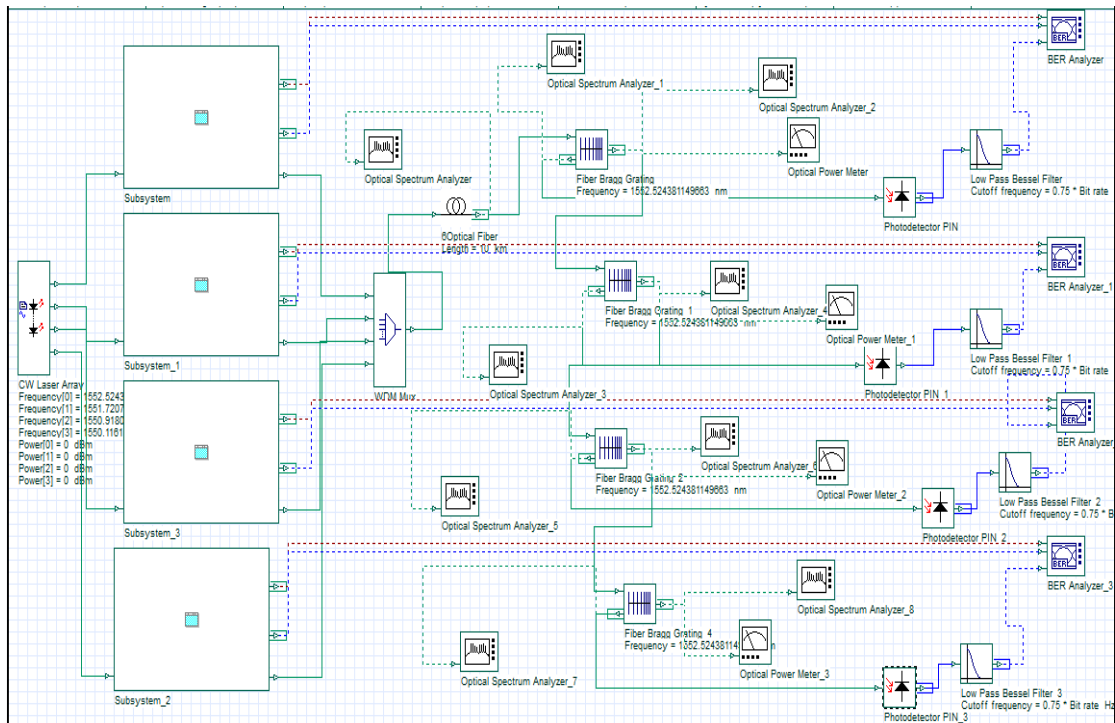

Figure (6): The designed model of simulated system in four regions FBG with Optisystem software.

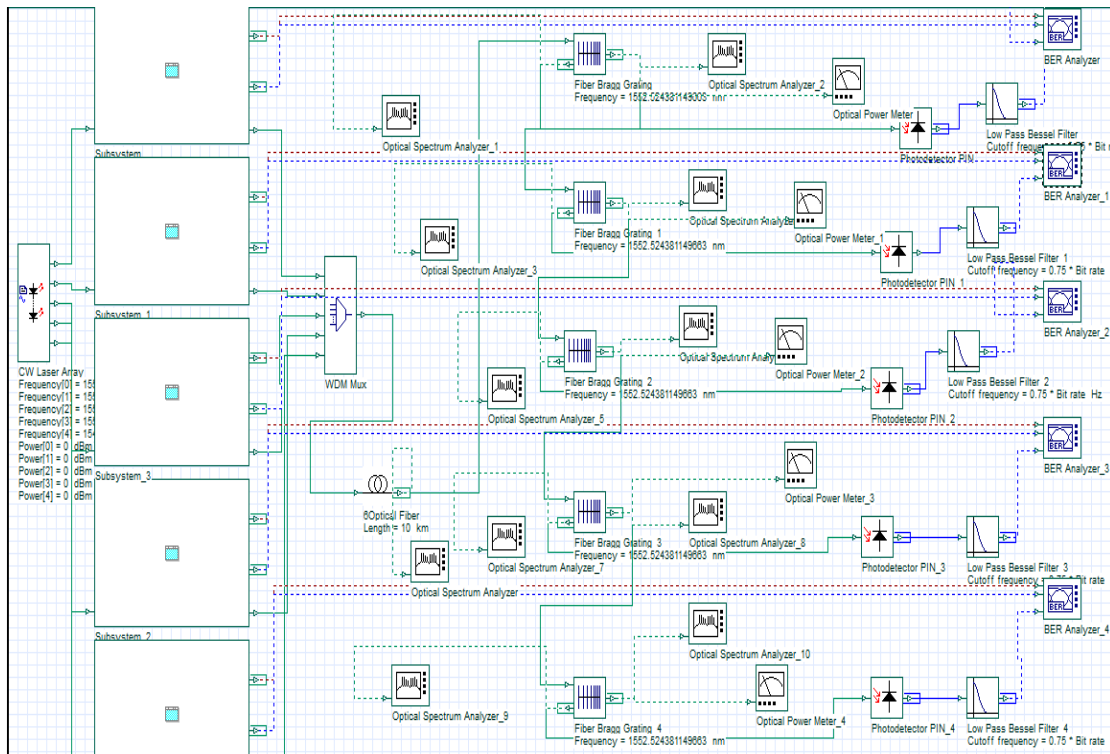

Figure (7): The designed model of simulated system in five regions FBG with Optisystem software.

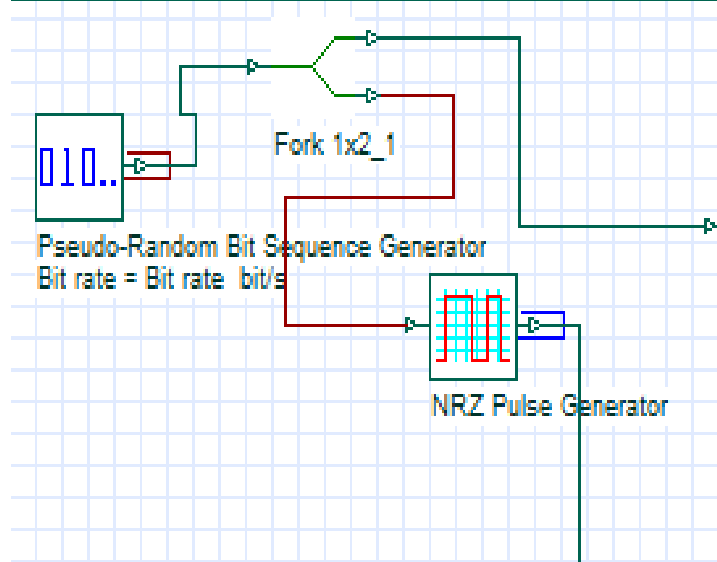
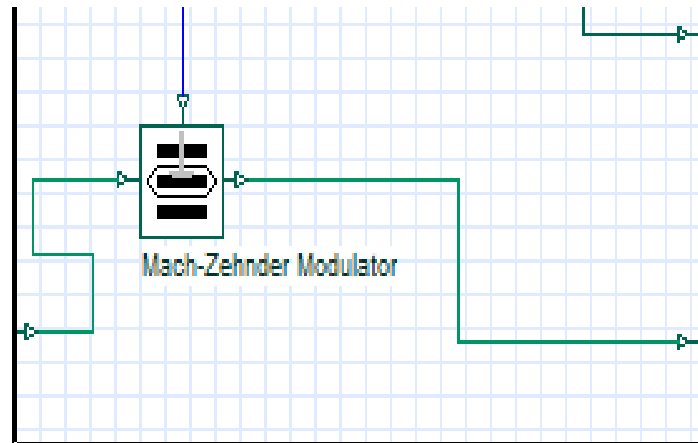

Figure (8): The electrical signal source



Figure(9): Mach-Zehnder modulator

The NRZ pulse generator generates a sequence of non-returnable pulses with a digital input signal represented by the PRBS generator. The fibers are then converted to the changed signal. The output of the fiber is sent to the Bragg fiber grating to compensate for the pressure. The PIN Photodiode detects Demux optical signals that transform electrical signals into optical signals. Then, various electric low-pass filters process each incoming signal to remove any redundant noise and increase the rate of signal bit error (BER) and the quality factor (Q factor). The optical fiber signal is then transferred to an FBG multiplexer based on WDM that filters each wavelength. At the end of the receiver, different electrical low pass filters are used. The demultiplexing filter eliminates noise from signals that are scrambled. Optical signals from a multiplexer are observed by a PIN photodiode. A Bessel low-pass filter then processes each incoming signal to eliminate any unwanted noise and thus increase the quality factor of the signal (Q Factor).

2. Results and discussion

Simulation and Design The effects of output power, signal power (dBm) and power (mwatt) on the receiver are tabulated using different values of input power (mwatt), attenuation coefficient (dB / km) and variable FBG length (mm). It is noted that the transmitted frequency range is large and has a high energy value when it exceeds the wavelength of 1550 nm. Notice that the energy value decreases at its edges and that the power value expressed by the FBG is small relative to the value reflected by the FBG region, as well as a minor difference between the energy values transmitted before and after the FBG region when the FBG region is used.

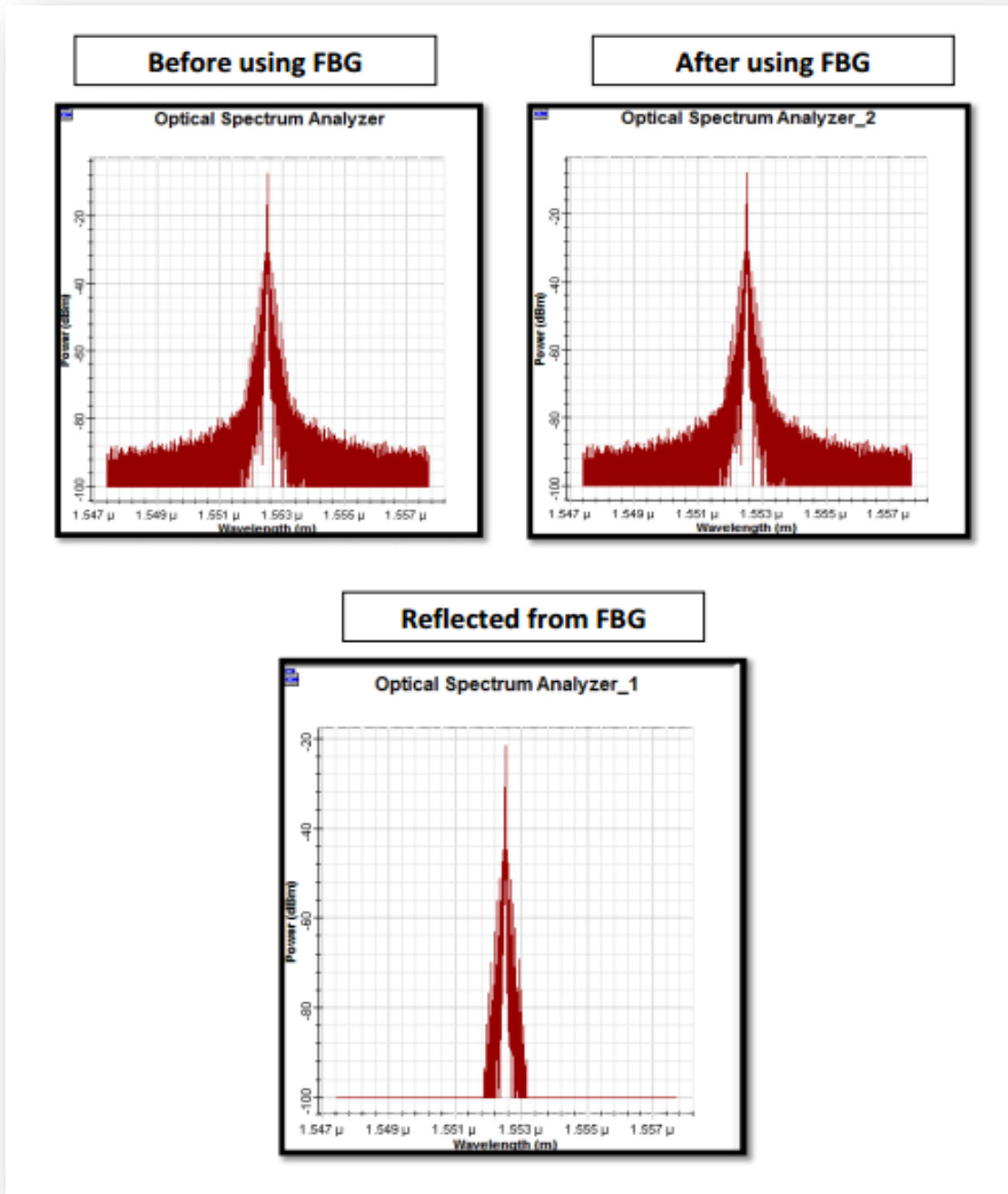
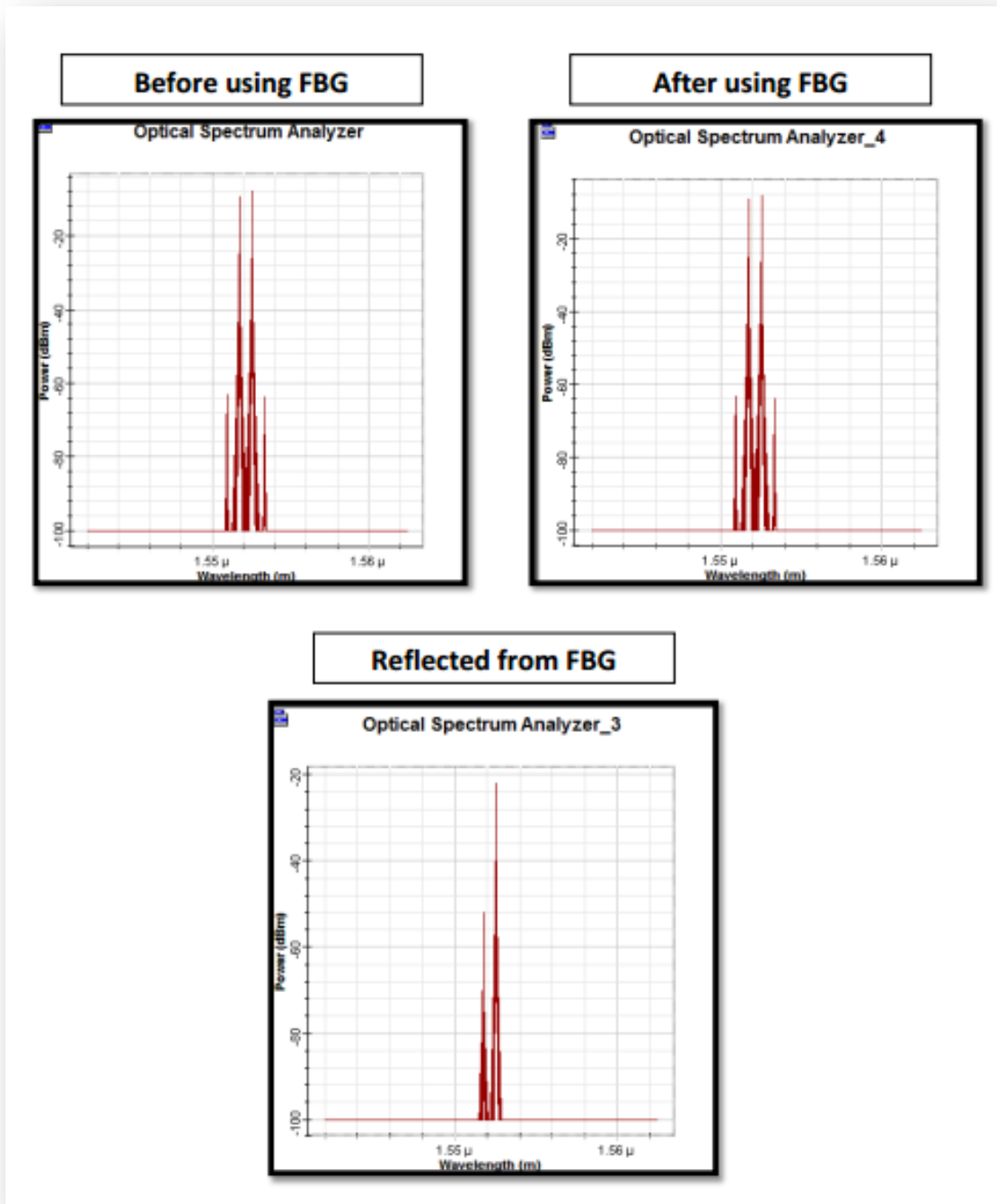

Figure (10-a): The output readings are measured by Optical power meter with (Transmitted and Reflected) and without using Fiber Bragg Grating in one region.



Figure(10-b):The output readings are measured by Optical power meter with(Transmitted and Reflected) and without using Fiber Bragg Grating in Two regions.

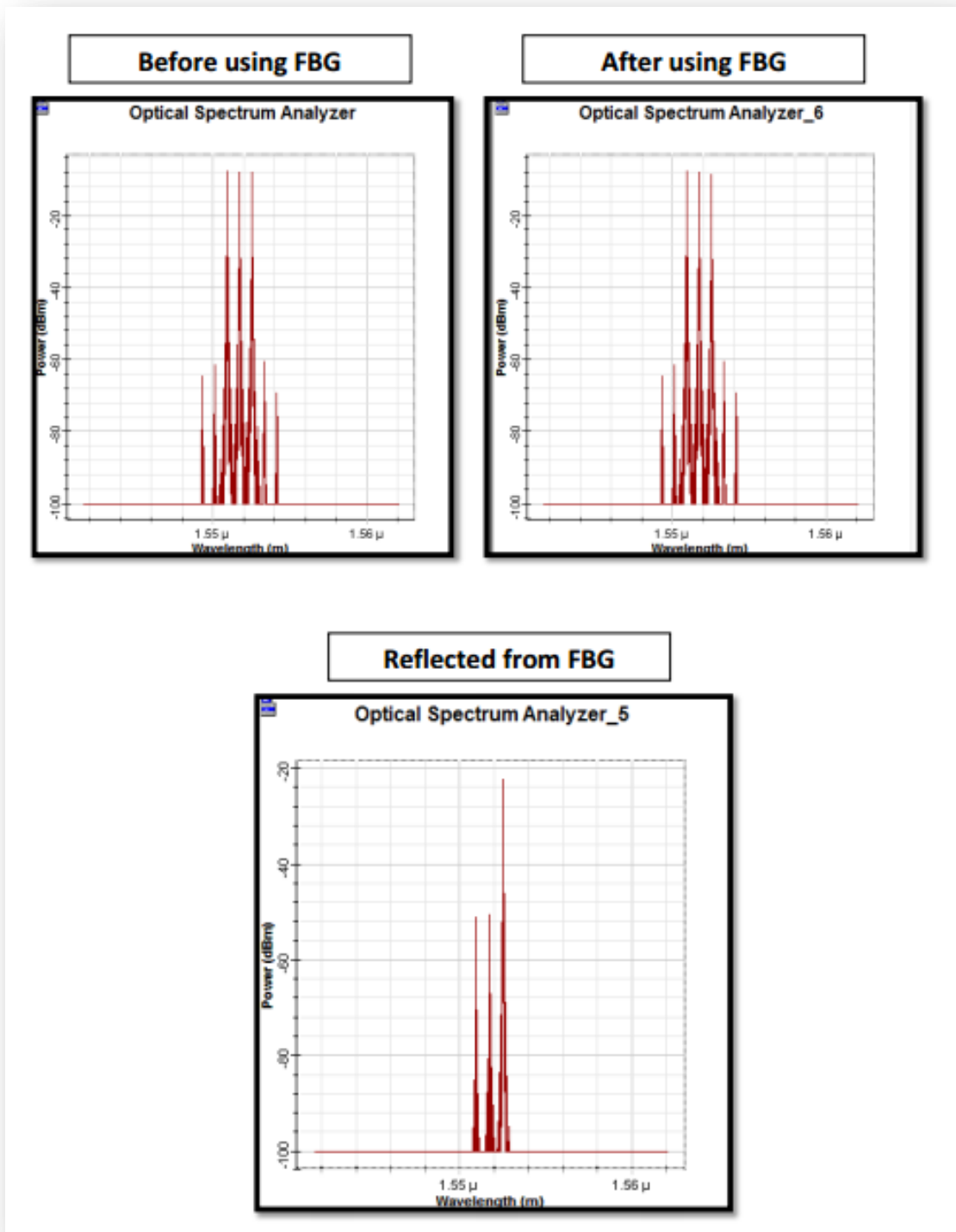

Figure (10-c): The output readings are measured by Optical power meter with(Transmitted and Reflected) and without using Fiber Bragg Grating in Three regions.

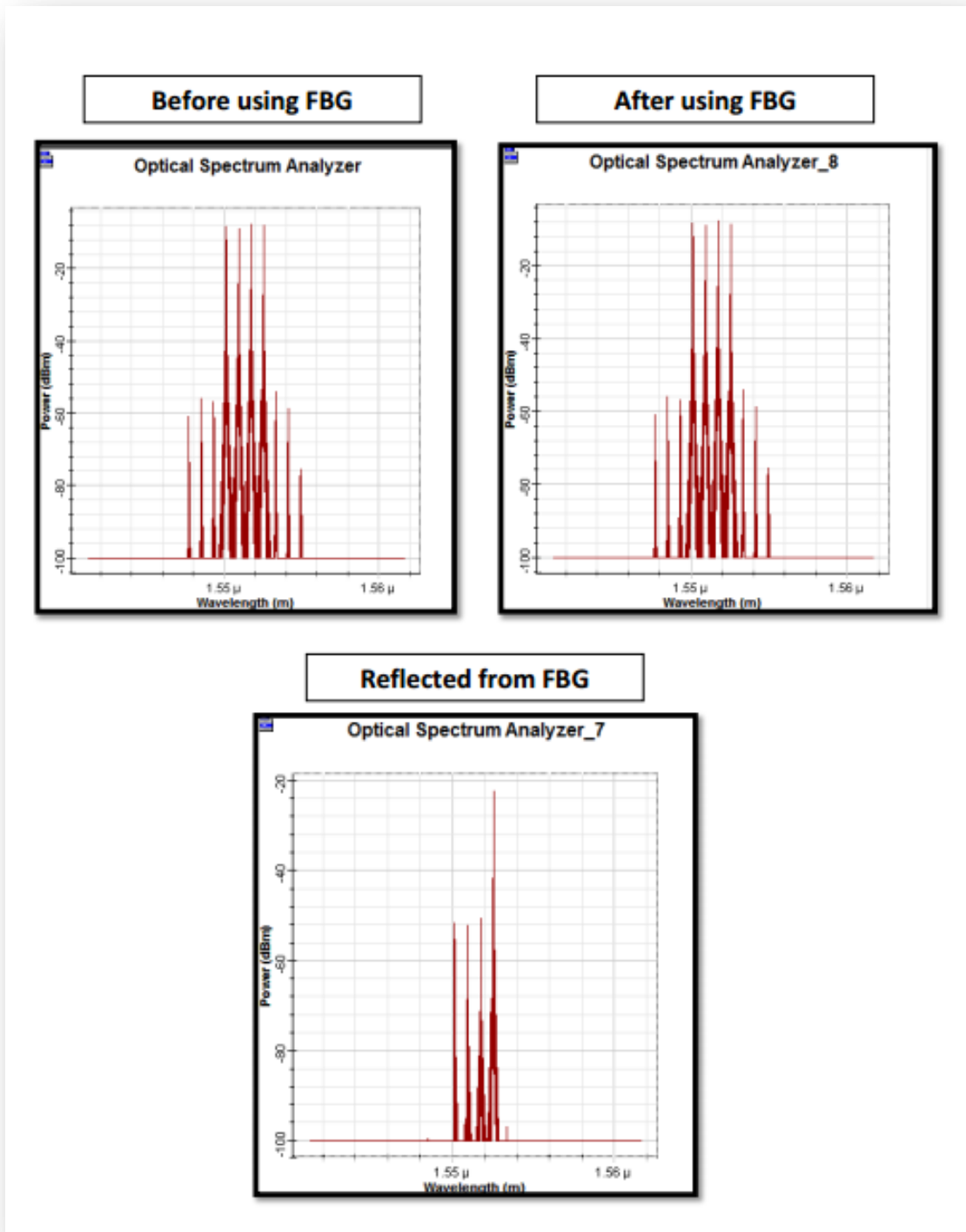

Figure (10-d): The output readings are measured by Optical power meter with(Transmitted and Reflected) and without using Fiber Bragg Grating in Four regions.

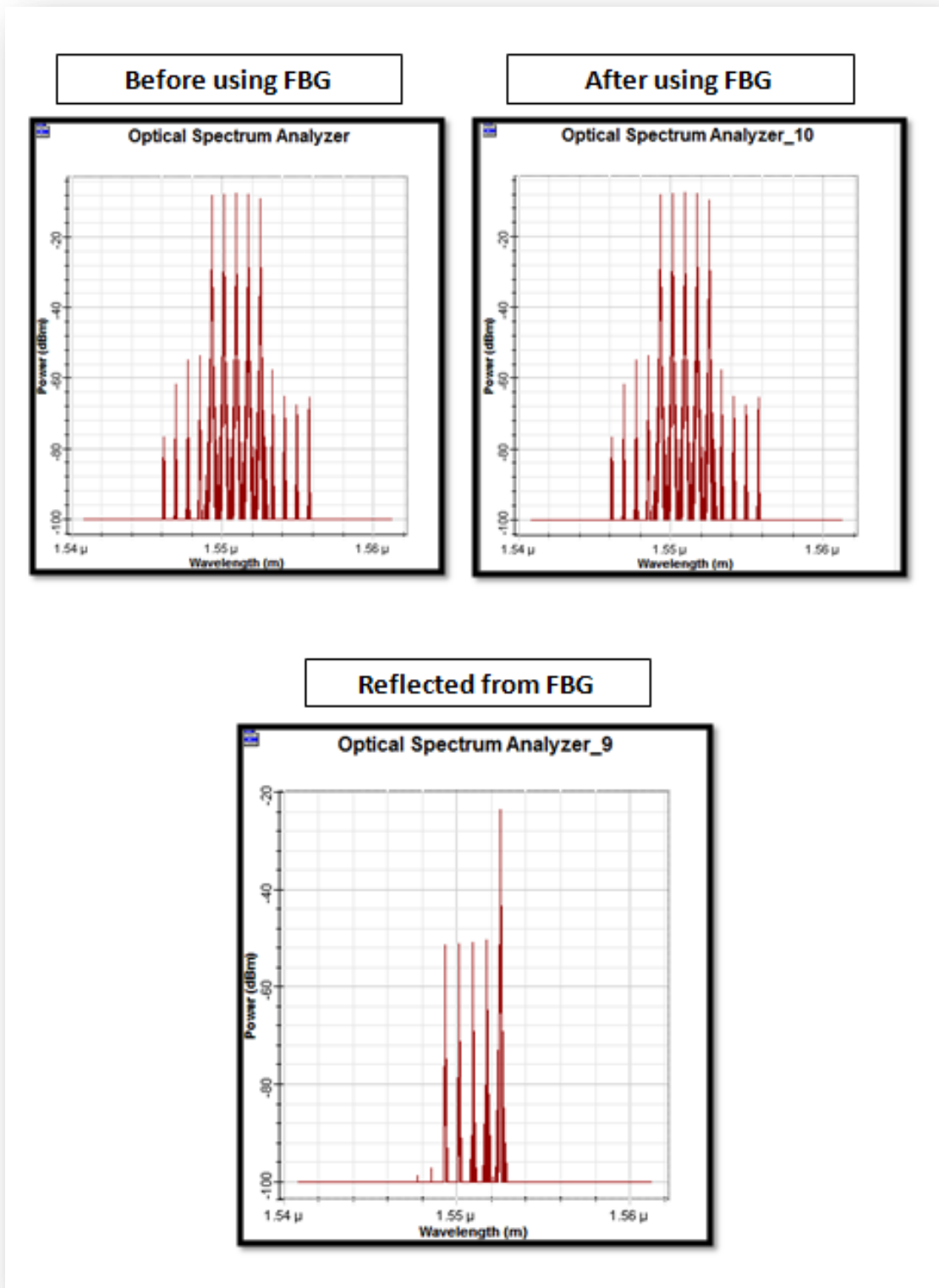

Figure (10-e): The output readings are measured by Optical power meter with(Transmitted and Reflected) and without using Fiber Bragg Grating in Five regions.

If the number of regions increases, we note that the number of columns increases in the reflected energy in five regions, leading to an increase in the distribution of reflected energy at wavelengths adjacent to 1550, which can cause data interference and loss.

From the outcome of the simulation given above, Transmittance / reflectivity was plotted against the wavelength of the various values of the grating regions, assuming effective refractive index of the fiber core $n_{\text{eff}} = 1.45$ and $L = 10$ mm. The wavelength of Bragg appears as sharp peaks reflected from the regions notched. Bragg wavelength data was obtained from the FBG simulation instruments datasheets. As the grid areas for FBG increase, the power and efficiency (density) of the Bragg output increase, and simulation results are displayed for input power (mW), output power (mW), the output power (dB) and the efficiency of the FBG transmitted / reflected spectrum adjustment shown in figures (10-a), (10-b), (10-c), (10-d) and (10-e).

Table (2): Simulation result of first design operation at FBG in Five regions.

Number. Of Regions	Input Power (mW)	Out put Power (mW)	Out put Power (dBm)	Efficiency (Intensity)(%)
One Grating region	1.808	0.295	- 5.299	16.316
Two Grating regions	1.808	0.546 0.536	- 2.620 - 2.707	30.199 29.646
Three Grating regions	1.808	0.824 0.814 0.804	- 0.836 - 0.892 - 0.946	45.575 45.022 44.469
Four Grating regions	1.808	1.102 1.091 1.081 1.071	0.421 0.380 0.339 0.300	60.951 60.342 59.789 59.236
Five regions	1.808	1.386 1.375 1.365 1.355 1.346	1.419 1.385 1.352 1.321 1.290	76.659 76.050 75.497 74.944 74.446

The results showed that the output power (mW) increases linearly as the number of network regions increases (Figures 11-13), the efficiency increases as the number of regions increases, and the efficiency of the FBG increases. By comparing the input and output of the laser source with the input power (1.808mW or 2.5dBm) by the power meter shown in table (1).

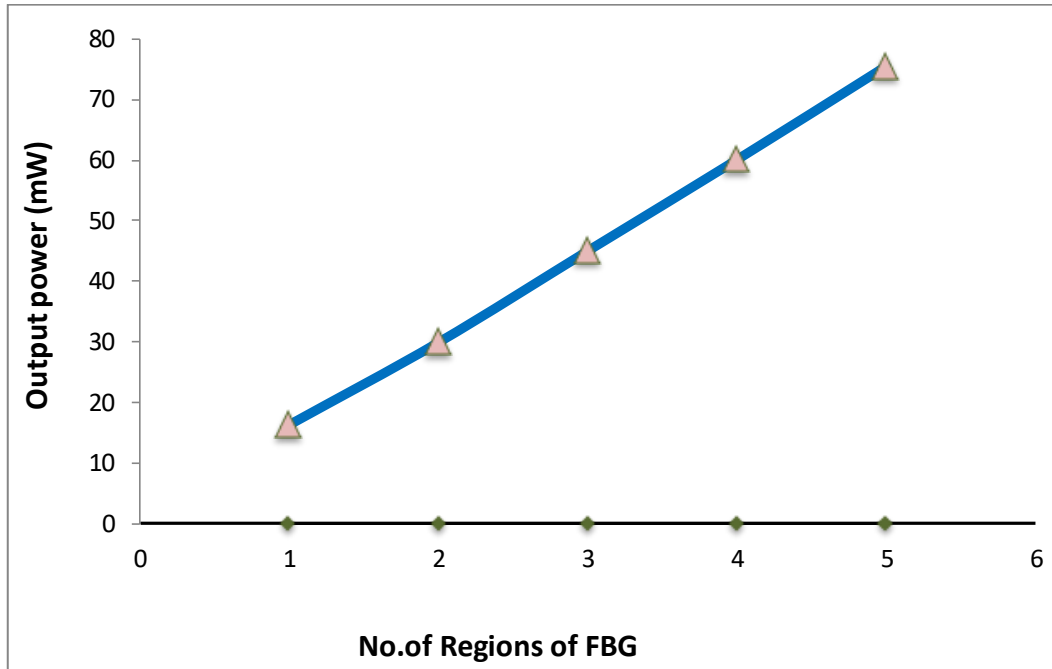

Figure (11): The output power (mW) versus Number of regions of FBG.

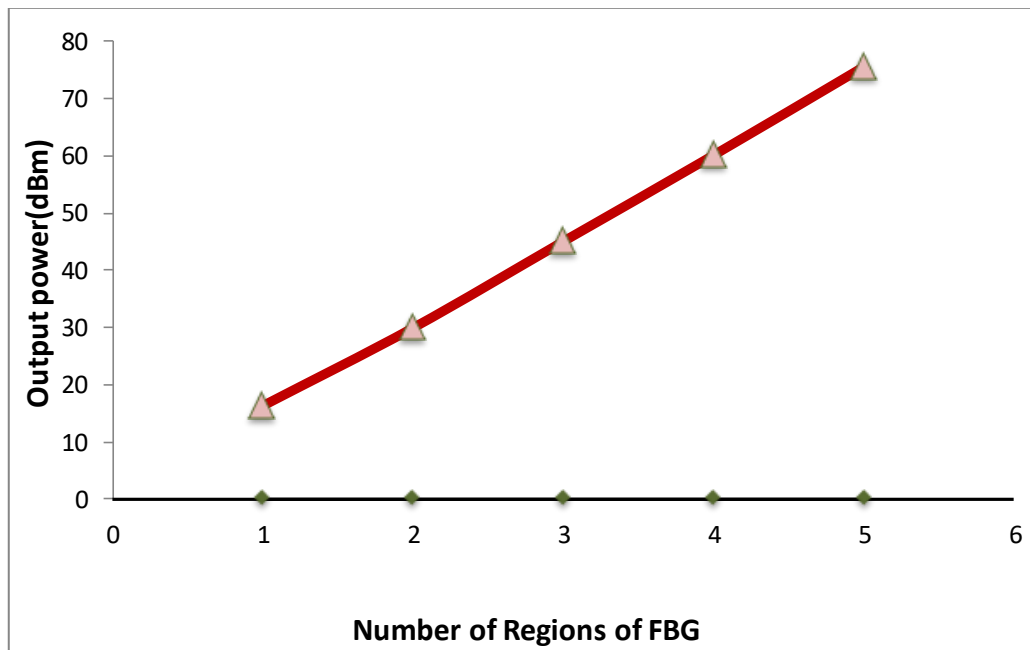
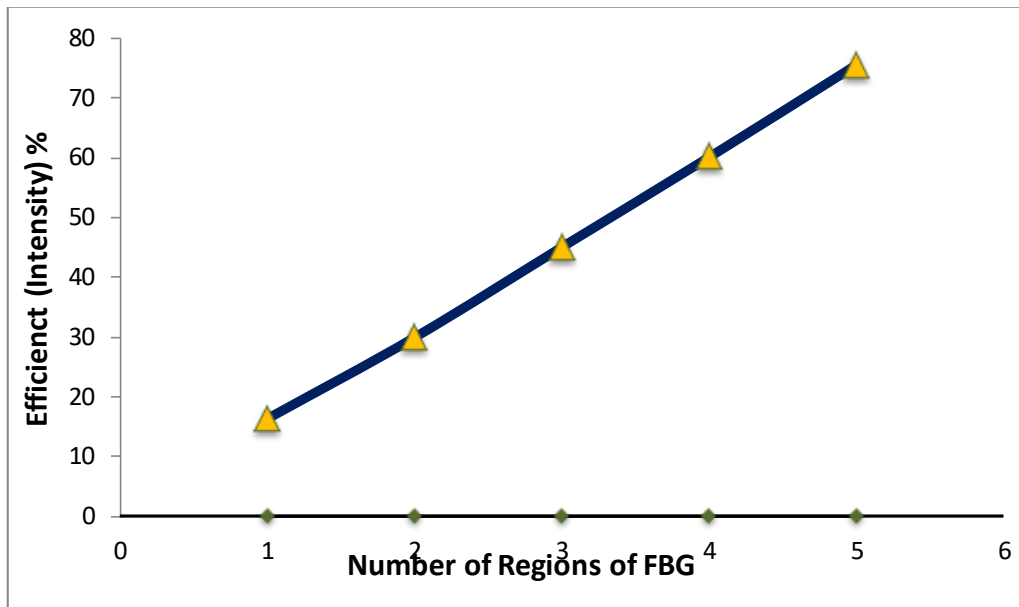

Figure (12): The output power (dB_m) versus Number of regions of FBG.



Figure(13): The Efficiency(Intensity%) figure versus Number of regions of FBG.

From the graphs above, it appears figure (13) that the efficiency increases with the increase in the number of the lattice area of the spectrum simulating the reflection, and this means that the relationship is linear with the output power and the number of FBG lattice regions, and we also observed that the energy increases with an increase in the number of regions, and the reason is that the increase in the number of grid regions lead to an increase in the number of reflected wavelengths, which leads to an increase in output power and bandwidth, and therefore to an increase in energy efficiency.

Attenuation coefficient (α) in figure (14), it can be seen that the attenuation was relatively high in the first and second regions, after which it started to decrease when adding the third region and it was lower in the fourth region and it started to increase again in the fifth region, but all values are good. The value of the attenuation factor depends on the transmit output power of the FBG which decreases as the number of regions increases. When mitigation reduces losses

The information in the cable decreases, as the zone number increases, the output power increases as shown in figure (15).

Table (3): Simulation result of first design operation at FBG in Five regions.

Number.of regions	Input power (mW)	Output Power (dBm)	Attenuation (α) (dBm/K m)
One Grating region	1.808	- 5.299	0.33
Two Grating regions	1.808	- 2.620 - 2.707	0.22
Three Grating regions	1.808	- 0.836 - 0.892 - 0.946	0.44
Four Grating regions	1.808	0.421 0.380 0.339 0.300	-0.8
Five regions	1.808	1.419 1.385 1.352	-0.2

		1.321	
		1.290	

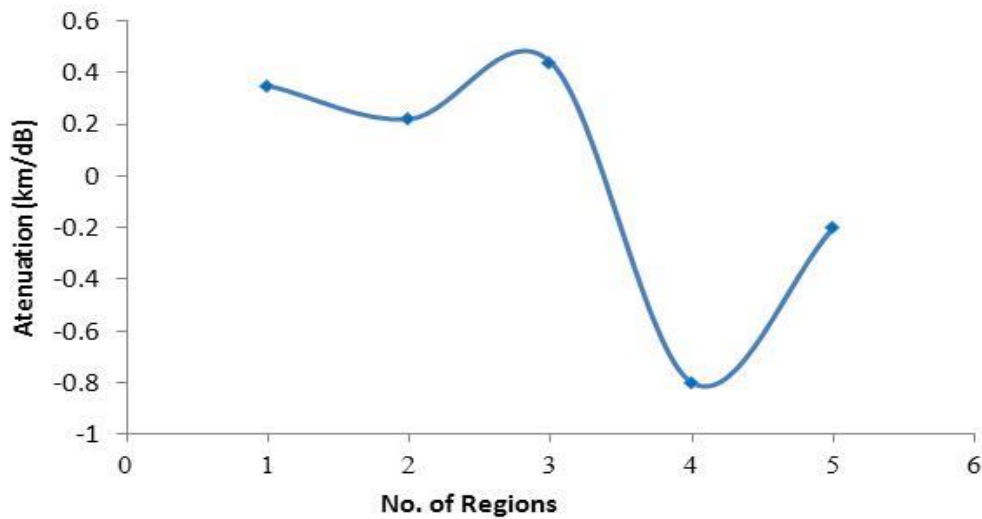

Figure (14): The attenuation(dBm/Km) versus with Number of regions of FBG.

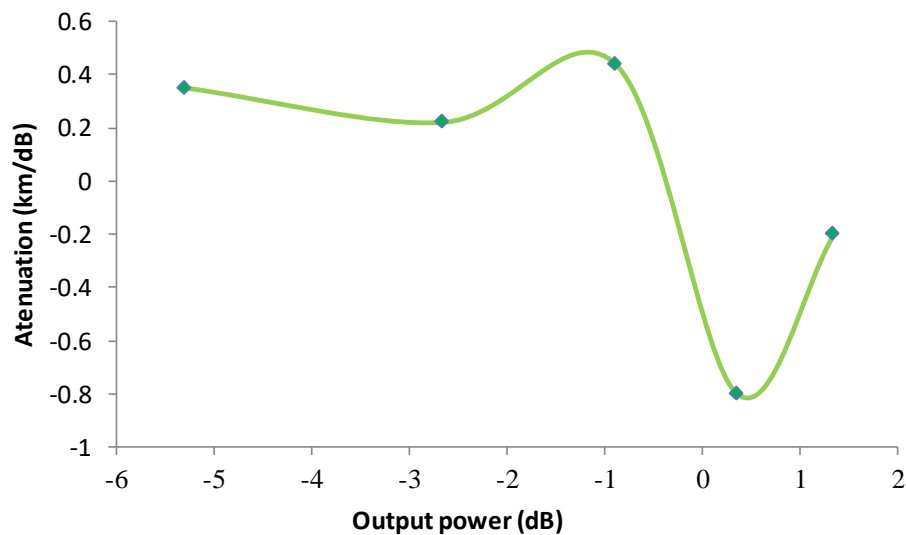

Figure (15): The attenuation versus with the power output .

3. Conclusion

Through this study, we note that this design has shown good performance and distinct characteristics through the terms of signal dispersion compensation and transmission traffic reduction, through the results obtained from the modeling of the system. optical transmission, in addition to the appropriate signal amplification when obtained by the PIN detector. For the optical receiver, signal degradation in optical fibers is the main disadvantage caused by dispersion, and there are several techniques used today to compensate for dispersion, such as optical fiber dispersion (SMF) and fiber dispersion. optical (FBG) which is supposed to be one of the most effective, to explain them. In truth, from the simulation results, the output power, input power and optical spectrum analyzer are calculated using (emitter and reflection) for all regions as well as the results of the WDM method. It got that first channel (1552,524nm) and ended at a frequency of (1549.315) nm, In the optisystem program, where the study of the resulting power behavior and power efficiency increases with the increase in the number

of grating areas of the FBG network, the efficiency of each species was studied, The increase in the number of network areas leads to an increase in the number of wavelengths reflected, leading to an increase in power efficiency and output power and, eventually, an increase in the number of wavelengths reflected.

References

- Chong Wing Keong, K R Subramanian, V K Dubey, "Optical Fiber System for Video and Telemetry Signal." Singapore Polytechnic, Electronics and Comm Engineering, School of Electrical and Electronic Engineering, Nanyang Technology University, Singapore.
- E. Gemzický a, J. Müllerová (2009) Numerical analysis of reflection characteristics of cascaded non-uniform fiber Bragg gratings," Department of Engineering Fundamentals, Faculty of Electrical Engineering, University of Žilina, Optical Sensors, Proc. of SPIE Vol.7356, 73561R.
- Fundamentals of Photonics, Fiber Optics in Telecommunication, Nick Massa Springfield Technical Community College Springfield, Massachusetts, University of Connecticut 2000.
- M.A. Othman¹, M.M. Ismail², H.A.Sulaiman³, M.H. Misran⁴, M.A. Meor Said⁵, Y.A. Rahim⁶, A.N. Che Pee⁷,M.R. Motsidi⁸, "An Analysis of 10 Gbits/s Optical Transmission System using Fiber Bragg Grating (FBG),"IOSR Journal of
- MohamadHasrulAriffin Bin MohdBadri, "A Cost Effective Broadband ASE Light Source Based FTTH", thesis, page 20-26.
- OptiSystem Getting Started, Optical Communication System Design Software,Version 3.0 for Windows® 2000/XP,Optiwave Corporation 2003.
- S. O. Mohammadi, Saeed Mozzaffari and M. Mahdi Shahidi, (2011). "Simulation of a transmission system to compensate dispersion in an optical fiber by chirp gratings." International Journal of the Physical Sciences, Vol. 6(32), pp. 7354- 7360, 2 December.
- Sawsan A. Abdul- Majid. 2011" Software Simulation FWM in WDM Optical Communication Systems," College of Information Technology-University of Koya Journal of Kirkuk University –Scientific Studies, vol.6, No.1,.